

CL2-B1/CL2-B1+ Chlorine Sensor

The CL2-B1 sensor is a PPM sensor that is designed for a broad variety of applications and instrumentation including portable gas detectors and fixed gas detection systems for industrial safety, environmental air quality and process control. This product is available in our standard format (CL2-B1) and with our patented Integrated Smart Technology (CL2-B1+) that has an IST board with a memory chip and temperature sensor integrated in the sensor. The + sensors store specific calibration, specification, and identification data on every sensor allowing plug and play operation. The on-board temperature sensor improves the accuracy and simplicity of temperature compensation algorithms.

CL2-B1 Chlorine Sensor – 3-Electrode

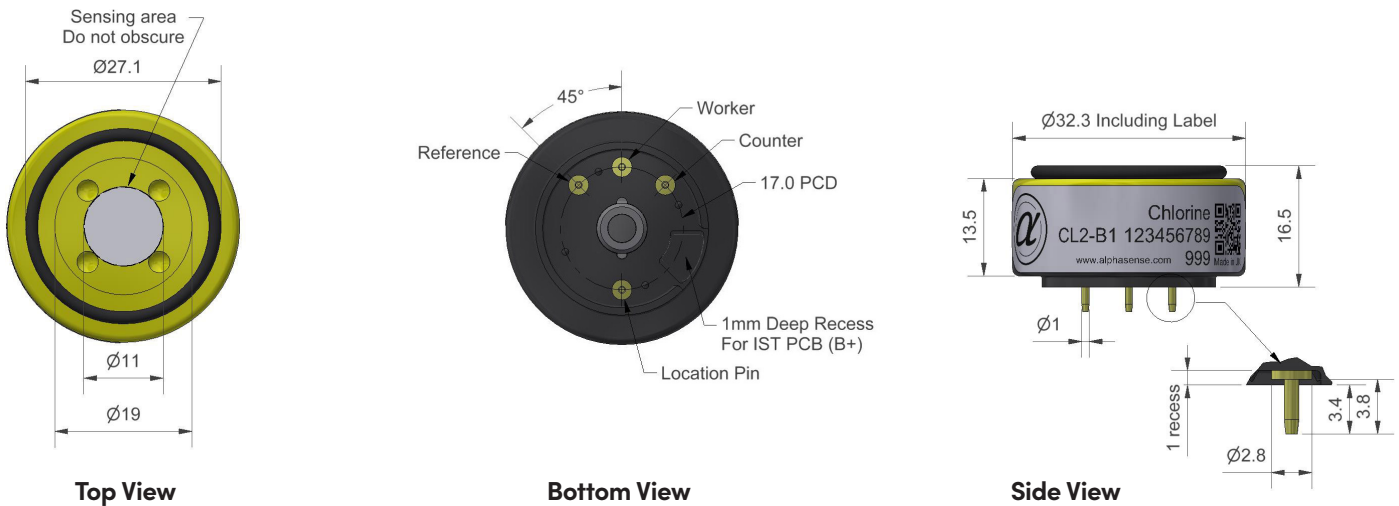

CL2-B1+ Chlorine Sensor – 3-Electrode (with Integrated Smart Technology)

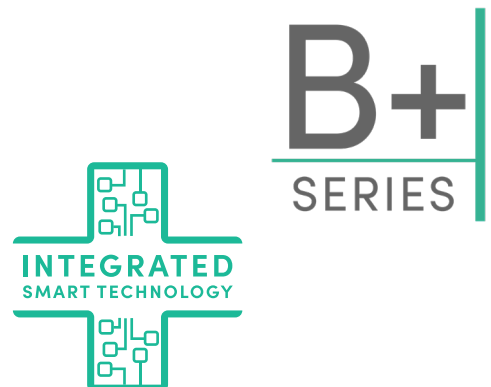
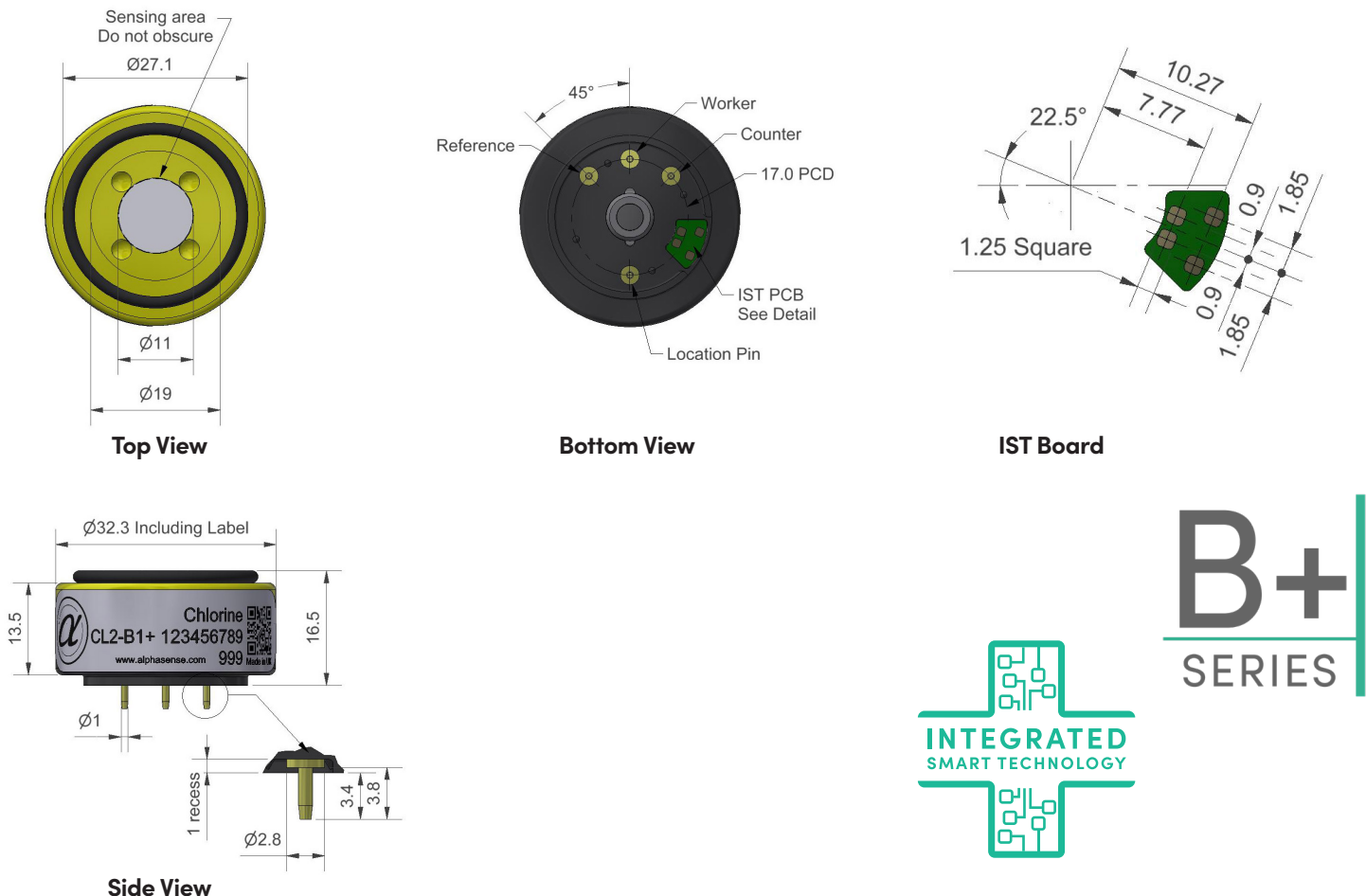

Dimensions are in millimetres (± 0.15 mm).

Sensor Data

Performance			
	Sensitivity	nA/ppm in 10ppm Cl ₂	-600 to -1150
	Response time	t90 (s) from zero to 10ppm Cl ₂ (33Ω load resistor)	< 60
	Zero current	ppm equivalent in zero air	± 0.4
	Resolution	RMS noise (ppm equivalent) (33Ω load resistor)	< 0.02
	Range	ppm limit of performance warranty	20
	Linearity	ppm error at full scale, linear at zero and 10ppm Cl ₂	< ± 0.2
	Overgas limit	maximum ppm for stable response to gas pulse	60

Lifetime			
	Zero drift	ppm equivalent change/year in lab air	< 0.03
	Sensitivity drift	% change/year in lab air, monthly test	< 6
	Operating life	months until 80% original signal (24-month warranted)	> 24

Environmental			
	Sensitivity @ -20°C	% (output @ -20°C/output @ 20°C) @ 10ppm	70 to 90
	Sensitivity @ 50°C	% (output @ 50°C/output @ 20°C) @ 10ppm	90 to 105
	Zero @ -20°C	ppm equivalent change from 20°C	< 0 to 0.1
	Zero @ 50°	ppm equivalent change from 20°C	< 0 to -1

Cross Sensitivity				
	H ₂ S sensitivity	% measured gas @ 20ppm	H ₂ S	< -300
	NO ₂ sensitivity	% measured gas @ 10ppm	NO ₂	< 120
	NO sensitivity	% measured gas @ 50ppm	NO	< 1
	SO ₂ sensitivity	% measured gas @ 20ppm	SO ₂	< -1
	CO sensitivity	% measured gas @ 400ppm	CO	< 0.1
	H ₂ sensitivity	% measured gas @ 400ppm	H ₂	< 0.1
	C ₂ H ₄ sensitivity	% measured gas @ 400ppm	C ₂ H ₄	< 0.1
	NH ₃ sensitivity	% measured gas @ 20ppm	NH ₃	< 0.1
	CO ₂ sensitivity	% measured gas @ 5% (Vol)	CO ₂	0

Key Specifications			
	Temperature range	°C	-20 to 50
	Pressure range	kPa	80 to 120
	Humidity range	% rh continuous (see note below)	15 to 90
	Storage period	months @ 3 to 20°C (stored in sealed pot)	6
	Load resistor	Ω (for optimum performance)	33
	Weight	g	< 13

Figure 1 Sensitivity Temperature Dependence

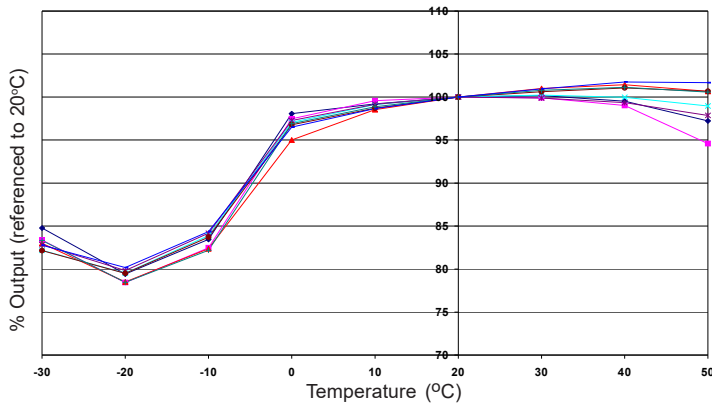

Figure 1 shows the variation in sensitivity caused by changes in temperature.

This data is taken from a typical batch of sensors. The mean and $\pm 95\%$ confidence intervals are shown.

Chlorine gas tests can be difficult and non-repeatable, especially at high temperatures.

Figure 2 Zero Temperature Dependence

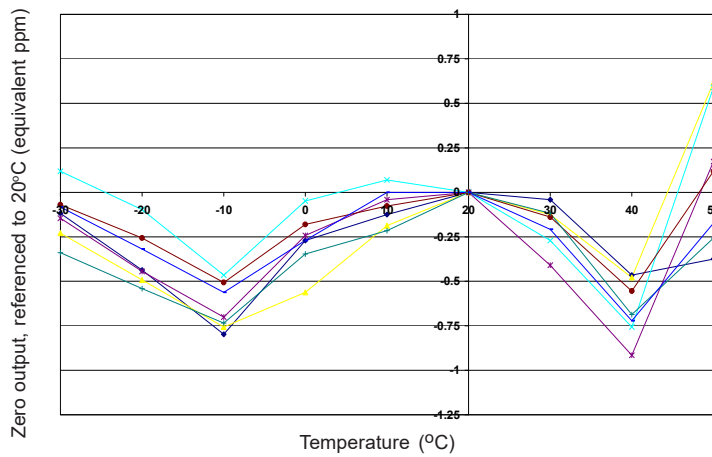

Figure 2 shows the variation in zero output caused by changes in temperature, expressed as ppm gas equivalent, referenced to zero at 20°C.

This data is taken from a typical batch of sensors.

Figure 3 Response to high gas concentrations

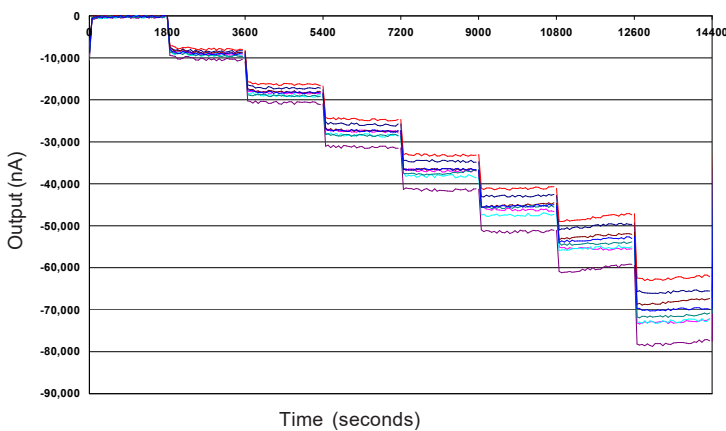

Figure 3 shows the CL₂-B1 stable response to chlorine gas, up to 80ppm. Sensors recover without any performance change when exposed to high gas concentrations for short periods.

IST Board Data

Interface	Communication Bus	Compatible with the 400 kHz I ² C protocol
	Max. Bus Speed	Up to 1 MHz
	Input Logic Levels	High (Recessive) < 2.3 V Low (Dominant) < 0.2 V
	Absolute Max. Input Signal	3.6 V
Electrical	Supply Voltage Range	1.7 V to 3.6 V
	Supply current – Stand-By	< 5 µA
	Supply current – Operating	< 0.15 mA (temperature reading only) < 2.15 mA (temperature reading + memory reading/writing)
	Power Supply Conditioning	Built-In 100 nF decoupling capacitor
	ESD Protection	4 kV (human body model) – Enhanced ESD / Latch-Up protection
	Bus Pins Input Capacitance	15 pF max.
Performance	Operational Temperature	-40 °C to +85 °C
	Temperature Sensor Accuracy	±1°C (-0°C to +70°C)
	Memory Data Retention	> 200 years
	Memory Write Cycles	> 4,000,000
Data & Communication	Memory IC & I2C Address	M24128X-FCU Device Address: R – 0xA0 / W – 0xA1
	Temperature IC & I2C Address	MAX31875R0TZS+T Device Address: R – 0x90 / W – 0x91
	Product Data Start Address	0x0900
	Calibration Data Start Address	0x0B00
	User Data Area	0x0D00 – 0x18FF (3,072 Bytes)
	CRC Polynomial	0x 01 04C1 1DB7
	Digital Signature Algorithm	SHA-256

Factory-populated data

Product Data
Data Format Version
Customer (OEM) ID
Product ID
Type of Sensor / Target Gas
Sensor Serial Number
End of Storage Period Date
Sensor Replacement Date
Product Data Checksum
Alphasense Digital Signature
Customer Digital Signature

Calibration
Calibration Data Units
Zero (clean dry air) Output
Calibration Span
Calibration Output
Sensitivity
Calibration Date
Calibration Data Checksum
Calibration Data Signature

Sensor Specification
Over-gas limit
Concentration Range
Temperature Range Low
Temperature Range High
Humidity Range Low
Humidity Range High
Pressure Range Low
Pressure Range High
Specification Checksum

15,000+ locations

Customer Specific
Custom Parameters
Re-Calibration Due Date
Operational Limits:
Low High STEL TWA
Next Bump Test Due Date
User Data Area

Note: Above 85% rh and 40°C a maximum continuous exposure period of 10 days is warranted. Where such exposure occurs the sensor will recover normal electrolyte volumes when allowed to rest at lower % rh and temperature levels for several days.

At the end of the product's life, do not dispose of any electronic sensor, component or instrument in the domestic waste, but contact the instrument manufacturer, Alphasense or its distributor for disposal instructions. NOTE: all sensors are tested at ambient environmental conditions unless otherwise stated. As applications of use are outside our control, the information provided is given without legal responsibility. Customers should test under their own conditions, to ensure that the sensors are suitable for their own requirements.

In the interest of continued product improvement, we reserve the right to change design features and specifications without prior notification. The data contained in this document is for guidance only. Alphasense Ltd accepts no liability for any consequential losses, injury or damage resulting from the use of this document or the information contained within. (©ALPHASENSE LTD) Doc. Ref. CL2-B1/FEB24