

## OX-B431/OX-B431+ Oxidising Gas Sensor – Ozone + Nitrogen Dioxide

The OX-B431 sensor is a PPB sensor that is designed for environmental air quality applications with best-in-class baseline stability. This product is available in our standard format (OX-B431) and with our patented Integrated Smart Technology (OX-B431+) that has an IST board with a memory chip and temperature sensor integrated in the sensor. The + sensors store specific calibration, specification, and identification data on every sensor allowing plug and play operation. The on-board temperature sensor improves the accuracy and simplicity of temperature compensation algorithms.

### OX-B431 Oxidising Gas Sensor – Ozone + Nitrogen Dioxide – 4-Electrode

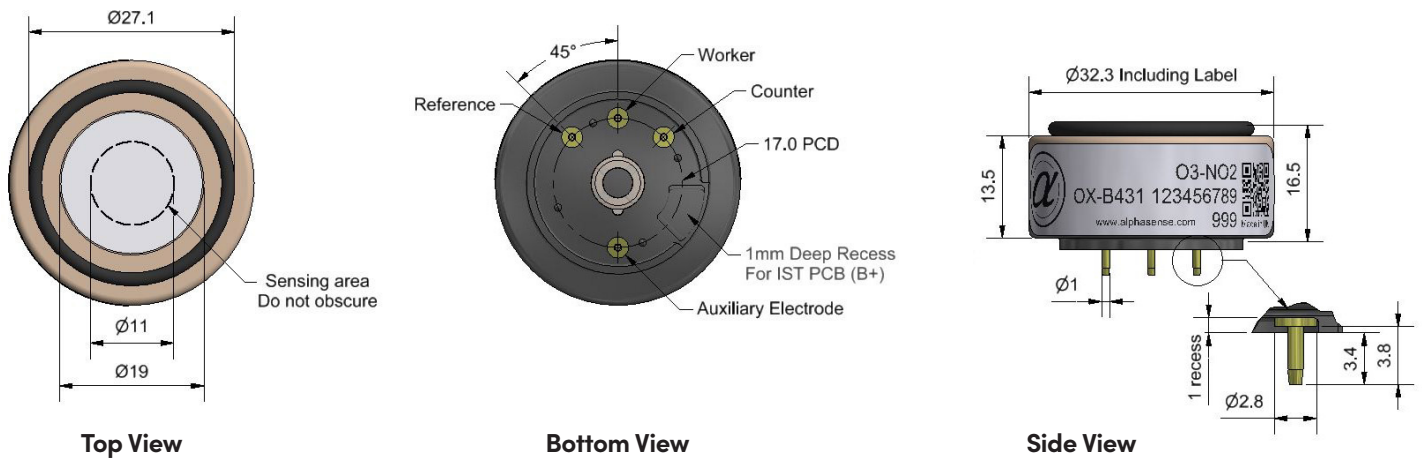

### OX-B431+ Oxidising Gas Sensor – Ozone + Nitrogen Dioxide – 4-Electrode (with Integrated Smart Technology)

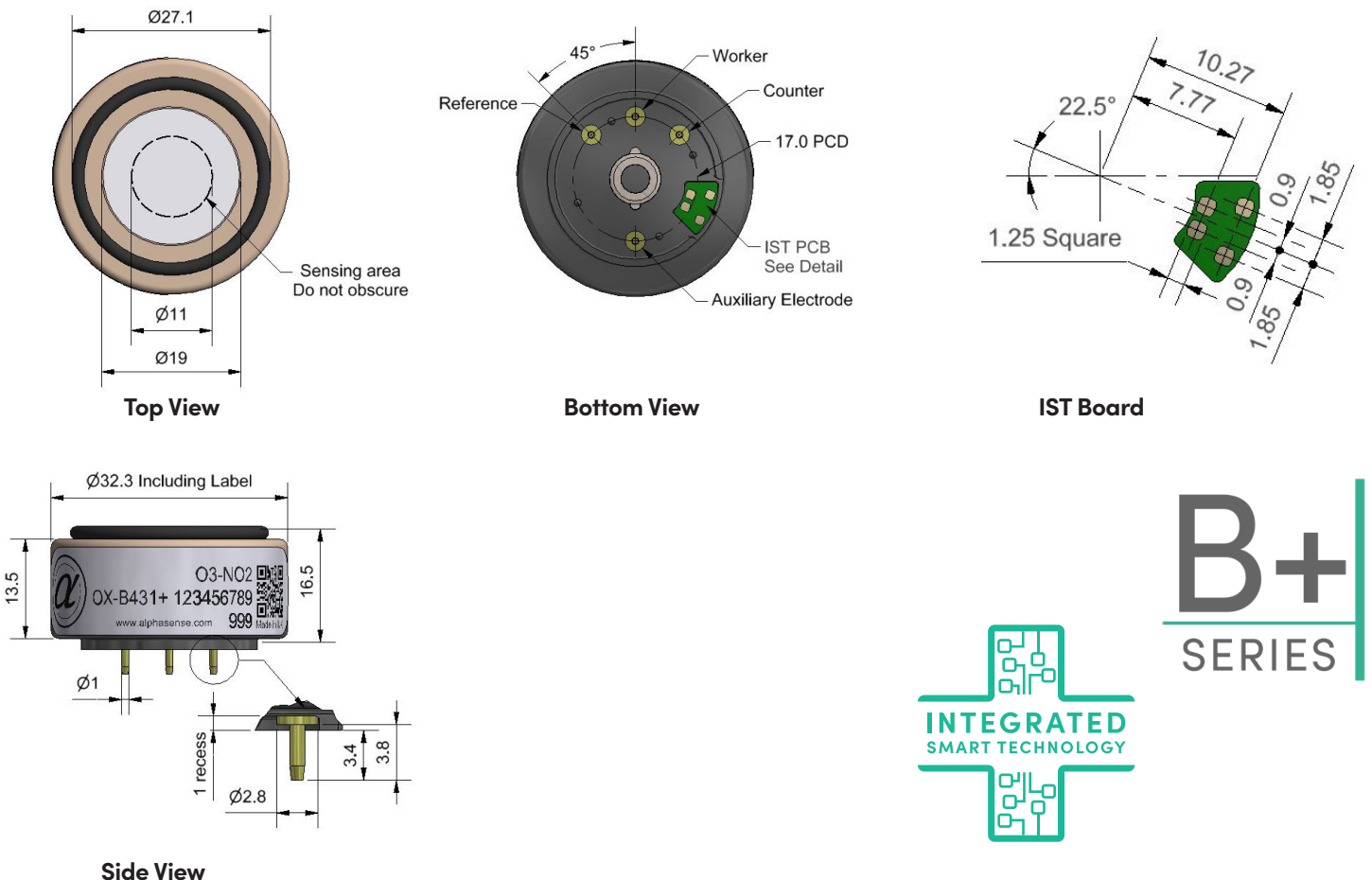

Dimensions are in millimetres (± 0.15 mm).

## Sensor Data - O<sub>3</sub>

### Specification O<sub>3</sub> Sensing

<b>Performance</b>	Sensitivity	nA/ppm at 1ppm O <sub>3</sub>	-225 to -750		
	Response time	t90 (s) from zero to 1ppm O <sub>3</sub>	< 80		
	Zero current	nA in zero air at 20°C	-80 to +80		
	Noise*	±2 standard deviations (ppb equivalent)	15		
	Range	ppm O <sub>3</sub> limit of performance warranty	20		
	Linearity	ppm error at full scale, linear at zero and 20ppm O <sub>3</sub>	< ± 0.5		
	Overgas limit	maximum ppm for stable response to gas pulse	50		
	<b>*Tested with Alphasense ISB low noise circuit</b>				
<b>Lifetime</b>	Zero drift	ppb equivalent change/year in lab air	0 to 20		
	Sensitivity drift	% change/year in lab air, monthly test	< -20 to -40		
	Operating life	months until 50% original signal (24-month warranted)	> 24		
<b>Environmental</b>	Sensitivity @ -20°C	% (output @ -20°C/output @ 20°C) @ 2ppm O <sub>3</sub>	70 to 90		
	Sensitivity @ 40°C	% (output @ 40°C/output @ 20°C) @ 2ppm O <sub>3</sub>	95 to 125		
	Zero @ -20°C	nA	0 to 25		
	Zero @ 40°C	nA	5 to 100		
<b>Cross Sensitivity</b>	H <sub>2</sub> S	sensitivity	% measured gas @ 5ppm	H <sub>2</sub> S	< -80
	NO	sensitivity	% measured gas @ 5ppm	NO	< 5
	Cl <sub>2</sub>	sensitivity	% measured gas @ 5ppm	Cl <sub>2</sub>	< 100
	SO <sub>2</sub>	sensitivity	% measured gas @ 5ppm	SO <sub>2</sub>	< -3
	CO	sensitivity	% measured gas @ 5ppm	CO	< -3
	C <sub>2</sub> H <sub>4</sub>	sensitivity	% measured gas @ 100ppm	C <sub>2</sub> H <sub>4</sub>	< 0.1
	NH <sub>3</sub>	sensitivity	% measured gas @ 20ppm	NH <sub>3</sub>	< 0.1
	H <sub>2</sub>	sensitivity	% measured gas @ 100ppm	H <sub>2</sub>	< 0.1
	CO <sub>2</sub>	sensitivity	% measured gas @ 5% volume	CO <sub>2</sub>	< 0.1
	Halothane	sensitivity	% measured gas @ 100ppm	Halothane	< 0.1
<b>Key Specifications</b>	Temperature range	°C	-30 to 40		
	Pressure range	kPa	80 to 120		
	Humidity range	% rh continuous	15 to 85		
	Storage period	months @ 3 to 20°C (stored in sealed pot)	6		
	Load resistor	Ω (AFE circuit is recommended)	33 to 100		
	Weight	g	< 13		

Figure 1 Sensitivity Temperature Dependence To 1ppm O<sub>3</sub>

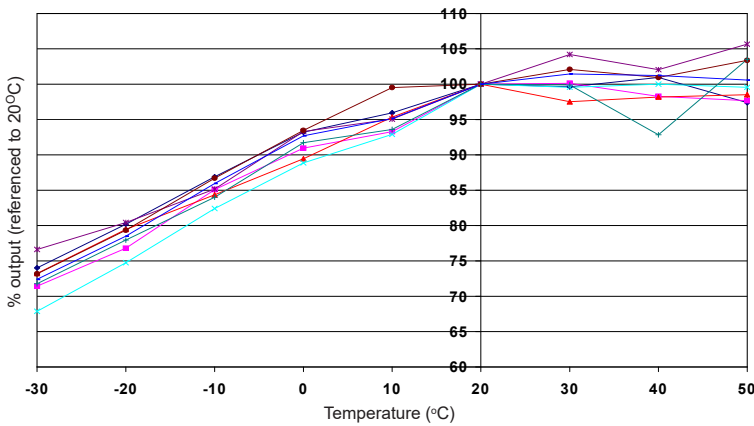

Figure 1 shows the temperature dependence of sensitivity at 1ppm O<sub>3</sub>.

This data is taken from a typical batch of sensors.

Figure 2 Zero Temperature Dependence

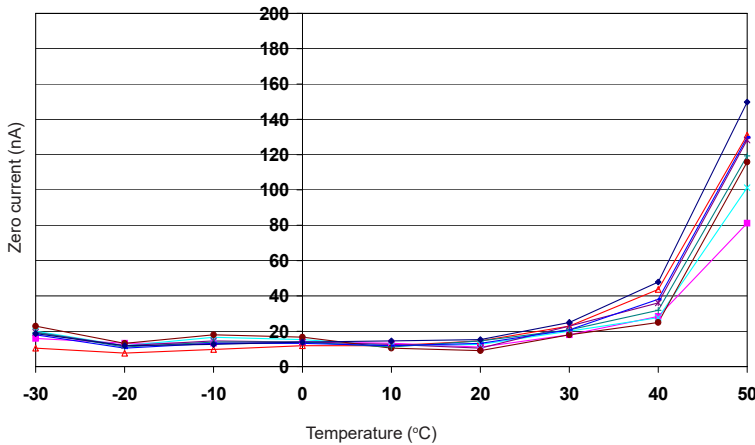

Figure 2 shows the variation in zero output of the working electrode caused by changes in temperature, expressed as nA.

This data is taken from a typical batch of sensors.

Contact Alphasense for further information on zero current correction.

Figure 3 Response from 200ppb to 0ppb O<sub>3</sub>

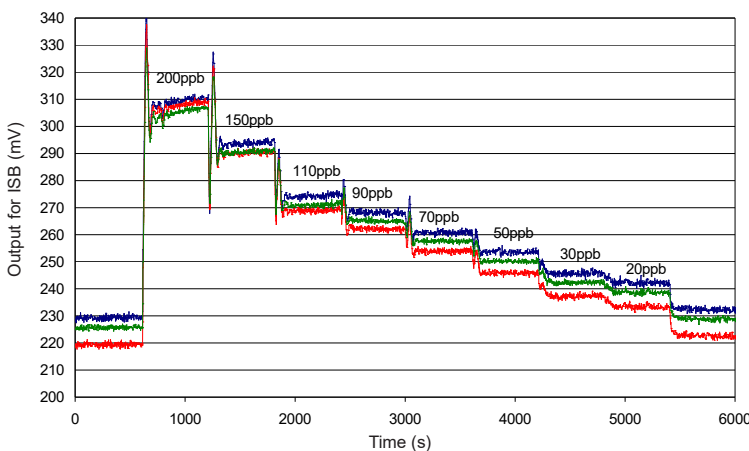

Figure 3 shows response from 200ppb O<sub>3</sub> to 0ppb O<sub>3</sub>.

Use of Alphasense ISB circuit reduces noise to 15ppb, with the opportunity of digital smoothing to reduce noise even further.

Offset voltage is due to intentional ISB circuit electronic offset.

## Sensor Data - NO<sub>2</sub>

The OX-B431 detects both ozone and nitrogen dioxide (O<sub>3</sub> + NO<sub>2</sub>). The NO2-B43F measures only nitrogen dioxide, filtering out ozone. Using these sensors together allows you to calculate the O<sub>3</sub> concentration by subtracting the corrected NO2-B43F concentration from the corrected OX-B431 concentration.

Before subtracting to determine ozone concentration, ensure that the signals from the two sensors have been corrected for electronic zero offset, sensor zero offset and temperature dependence, and sensitivity (nA/ppm) calibration and temperature dependence.

### Specification NO<sub>2</sub> Sensing

<b>Performance</b>	Sensitivity to NO <sub>2</sub>	nA/ppm at 2ppm NO <sub>2</sub>	-250 to -750		
	Response time	t90 (s) from zero to 2ppm NO <sub>2</sub>	< 80		
	Zero current	nA in zero air at 20°C	-80 to +80		
	Noise*	±2 standard deviations (ppb equivalent)	15		
	Range	ppm NO <sub>2</sub> limit of performance warranty	20		
	Linearity	ppm error at full scale, linear at zero and 20ppm NO <sub>2</sub>	< ± 0.5		
	Overgas limit	maximum ppm for stable response to gas pulse	50		
	<b>*Tested with Alphasense ISB low noise circuit</b>				
<b>Lifetime</b>	Zero drift	ppb equivalent change/year in lab air	0 to 20		
	Sensitivity drift	% change/year in lab air, monthly test	< -20 to -40		
	Operating life	months until 50% original signal (24-month warranted)	> 24		
<b>Environmental</b>	Sensitivity @ -20°C	% (output @ -20°C/output @ 20°C) @ 2ppm NO <sub>2</sub>	70 to 90		
	Sensitivity @ 40°C	% (output @ 50°C/output @ 20°C) @ 2ppm NO <sub>2</sub>	95 to 110		
	Zero @ -20°C	nA	0 to 25		
	Zero @ 40°C	nA	5 to 50		
<b>Cross Sensitivity</b>	H <sub>2</sub> S	sensitivity	% measured gas @ 5ppm	H <sub>2</sub> S	< -80
	NO	sensitivity	% measured gas @ 5ppm	NO	< 5
	Cl <sub>2</sub>	sensitivity	% measured gas @ 5ppm	Cl <sub>2</sub>	< 100
	SO <sub>2</sub>	sensitivity	% measured gas @ 5ppm	SO <sub>2</sub>	< -3
	CO	sensitivity	% measured gas @ 5ppm	CO	< -3
	C <sub>2</sub> H <sub>4</sub>	sensitivity	% measured gas @ 100ppm	C <sub>2</sub> H <sub>4</sub>	< 0.1
	NH <sub>3</sub>	sensitivity	% measured gas @ 20ppm	NH <sub>3</sub>	< 0.1
	H <sub>2</sub>	sensitivity	% measured gas @ 100ppm	H <sub>2</sub>	< 0.1
	CO <sub>2</sub>	sensitivity	% measured gas @ 5% volume	CO <sub>2</sub>	< 0.1
	Halothane	sensitivity	% measured gas @ 100ppm	Halothane	< 0.1
<b>Key Specifications</b>	Temperature range	°C	-30 to 40		
	Pressure range	kPa	80 to 120		
	Humidity range	% rh continuous	15 to 85		
	Weight	g			

**Figure 4 Sensitivity temperature dependence to 2ppm NO<sub>2</sub>**

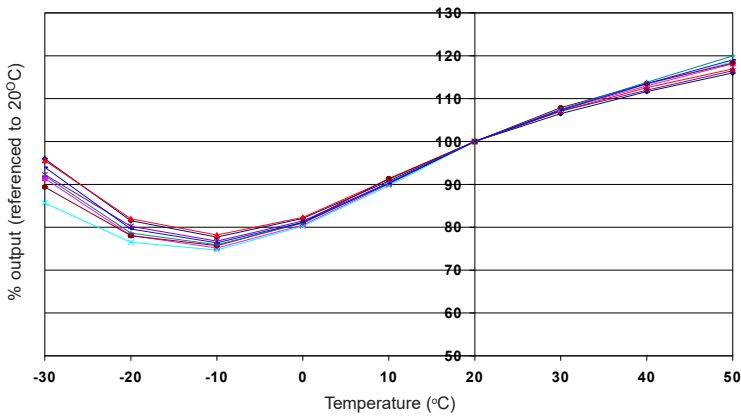

Figure 4 shows the temperature dependence of sensitivity at 2ppm NO<sub>2</sub>.  
This data is taken from a typical batch of sensors.

**Figure 5 Response to 50ppb NO<sub>2</sub>**

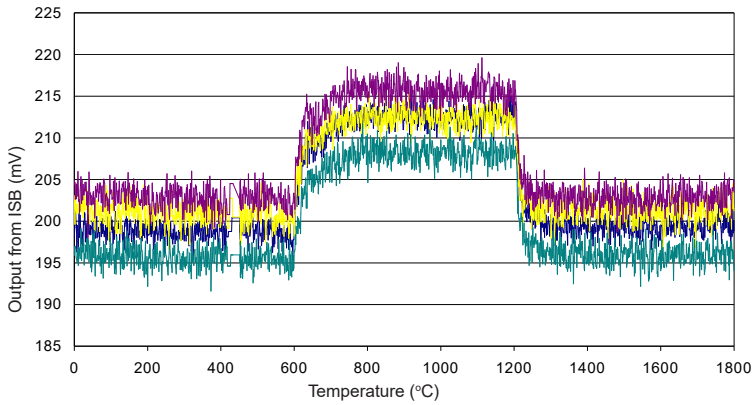

Figure 5 shows the fast response and good baseline recovery of the OX-B431 to 50ppb NO<sub>2</sub>.

**Figure 6 Response from 200ppb to 0ppb NO<sub>2</sub>**

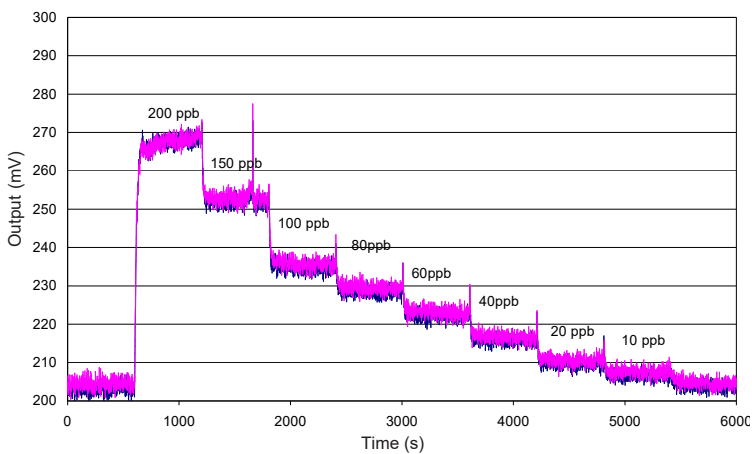

Figure 6 shows response from 200ppb NO<sub>2</sub> to 0ppb NO<sub>2</sub>.  
Use of Alphasense ISB circuit reduces noise to 15ppb, with the opportunity of digital smoothing to reduce noise to less than ± 5ppb.  
Offset voltage is due to intentional ISB circuit electronic offset.

## IST Board Data

<b>Interface</b>	Communication Bus	Compatible with the 400 kHz I <sup>2</sup> C protocol
	Max. Bus Speed	Up to 1 MHz
	Input Logic Levels	High (Recessive) < 2.3 V   Low (Dominant) < 0.2 V
	Absolute Max. Input Signal	3.6 V

<b>Electrical</b>	Supply Voltage Range	1.7 V to 3.6 V
	Supply current – Stand-By	< 5 µA
	Supply current – Operating	< 0.15 mA (temperature reading only) < 2.15 mA (temperature reading + memory reading/writing)
	Power Supply Conditioning	Built-In 100 nF decoupling capacitor
	ESD Protection	4 kV (human body model) – Enhanced ESD / Latch-Up protection
	Bus Pins Input Capacitance	15 pF max.

<b>Performance</b>	Operational Temperature	-40 °C to +85 °C
	Temperature Sensor Accuracy	±1°C (-0°C to +70°C)
	Memory Data Retention	> 200 years
	Memory Write Cycles	> 4,000,000

<b>Data &amp; Communication</b>	Memory IC & I2C Address	M24128X-FCU   Device Address: R – 0xA0 / W – 0xA1
	Temperature IC & I2C Address	MAX31875R0TZS+T   Device Address: R – 0x90 / W – 0x91
	Product Data Start Address	0x0900
	Calibration Data Start Address	0x0B00
	User Data Area	0x0D00 – 0x18FF (3,072 Bytes)
	CRC Polynomial	0x 01 04C1 1DB7
	Digital Signature Algorithm	SHA-256

### Factory-populated data

<b>Product Data</b>
Data Format Version
Customer (OEM) ID
Product ID
Type of Sensor / Target Gas
Sensor Serial Number
End of Storage Period Date
Sensor Replacement Date
Product Data Checksum
Alphasense Digital Signature
Customer Digital Signature

<b>Calibration</b>
Calibration Data Units
Zero (clean dry air) Output
Calibration Span
Calibration Output
Sensitivity
Calibration Date
Calibration Data Checksum
Calibration Data Signature

<b>Sensor Specification</b>
Over-gas limit
Concentration Range
Temperature Range Low
Temperature Range High
Humidity Range Low
Humidity Range High
Pressure Range Low
Pressure Range High
Specification Checksum

### 15,000+ locations

<b>Customer Specific</b>
Custom Parameters
Re-Calibration Due Date
Operational Limits:
Low   High   STEL   TWA
Next Bump Test Due Date
User Data Area

NOTE: All sensors are tested at ambient environmental conditions, with 47 ohm load resistor, unless otherwise stated. As applications of use are outside our control, the information provided is given without legal responsibility. Customers should test under their own conditions, to ensure that the sensors are suitable for their own requirements.

At the end of the product's life, do not dispose of any electronic sensor, component or instrument in the domestic waste, but contact the instrument manufacturer, Alphasense or its distributor for disposal instructions. NOTE: all sensors are tested at ambient environmental conditions unless otherwise stated. As applications of use are outside our control, the information provided is given without legal responsibility. Customers should test under their own conditions, to ensure that the sensors are suitable for their own requirements.

In the interest of continued product improvement, we reserve the right to change design features and specifications without prior notification. The data contained in this document is for guidance only. Alphasense Ltd accepts no liability for any consequential losses, injury or damage resulting from the use of this document or the information contained within. (©ALPHASENSE LTD) Doc. Ref. OX-B431/FEB24